

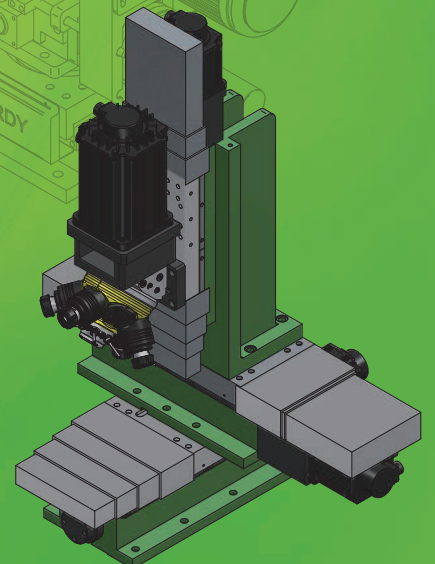

**HANN KUEN
MACHINERY
& HARDWARE**

**dolphin
EXPORTS**

ISO 9001:2015 CERTIFIED COMPANY

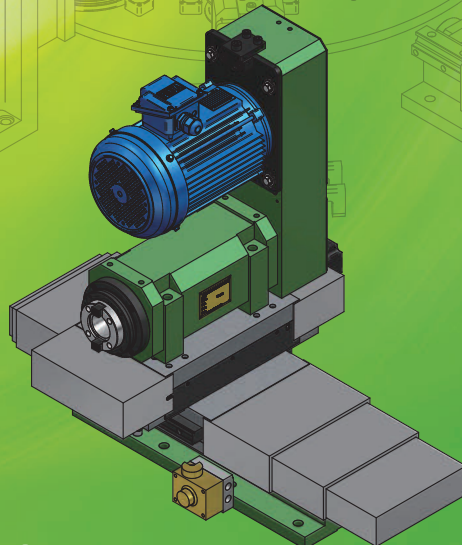
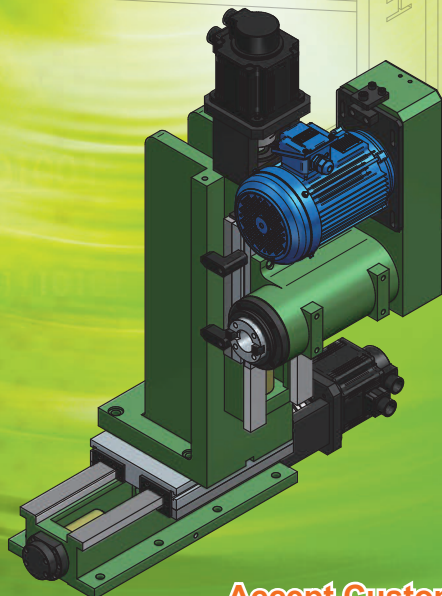
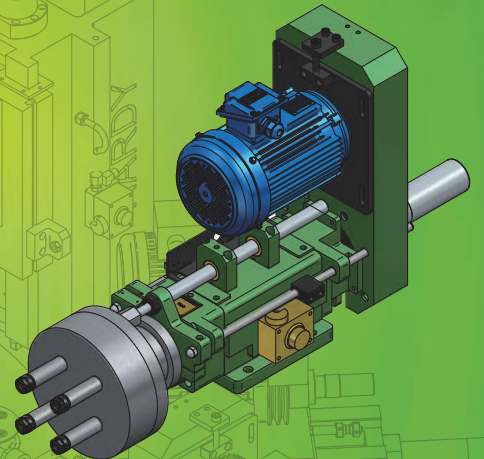
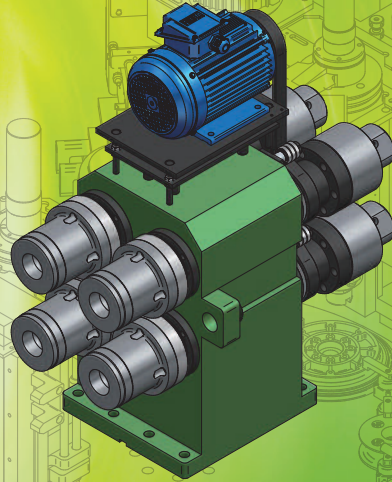
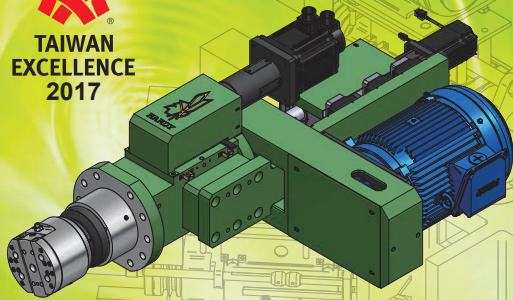
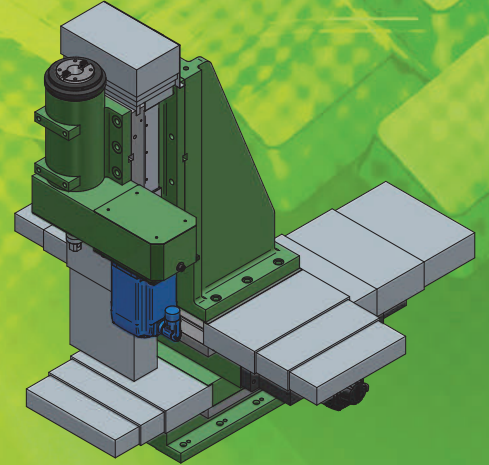
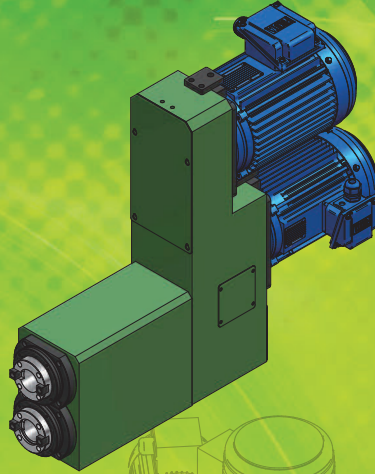
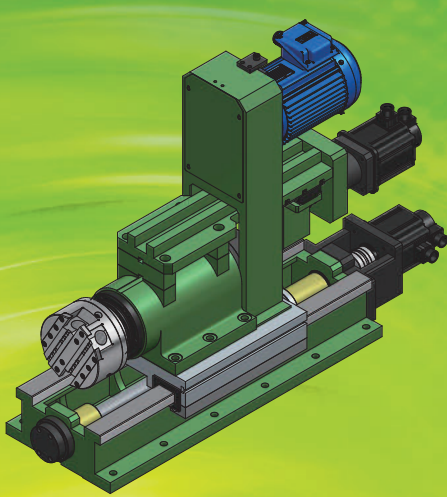

Accept Customize Order

Drilling / Tapping Spindle Head-Servo Type



Roundness: $\leq 0.003\text{mm}$

Model	Max. Capacity (S45C)	Travel mm	Spindle Taper	Max. RPM
SSD03-60	$\phi 6\text{ mm}$	60mm	ER16, KH14E JT1, JT2	10000
SSD03-80		80mm		
SSD05-85	$\phi 13\text{ mm}$	85mm	ER20, JT6	5000
SSD06-100	$\phi 20\text{ mm}$	100mm	JT6, ER25, ER32 HSK40	3500, 10000

Roundness: $\leq 0.003\text{mm}$

Model	Max. Capacity (S45C)	Travel mm	Spindle Taper	Max. RPM
SSD09-120	$\phi 25\text{ mm}$	120mm	NT30, HSK50	3000, 8000
SSD12-150	$\phi 35\text{ mm}$	150mm	NT40, HSK63	2000, 6000
SSD15-150	$\phi 50\text{ mm}$	150mm	NT50, HSK80	1600, 4000

Drilling / Tapping Spindle Head-Servo / Flange Type

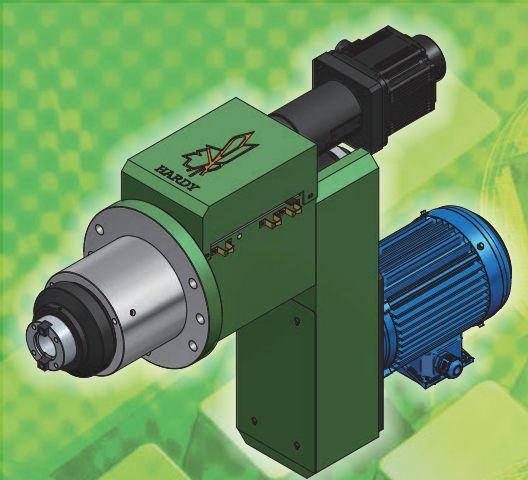

Roundness: $\leq 0.003\text{mm}$

Model	Max. Capacity (S45C)	Travel mm	Spindle Taper	Max. RPM
SFSD06-100	$\phi 16\text{ mm}$	100mm	JT6, ER25, HSK40	3500, 10000
SFSD09-120	$\phi 25\text{ mm}$	120mm	NT30, HSK50	3000, 8000
SFSD11-120	$\phi 35\text{ mm}$	120mm	NT40	1600, 5000
SFSD12-150	$\phi 35\text{ mm}$	150mm	NT40, HSK63	2000, 5000
SFSD15-150	$\phi 50\text{ mm}$	150mm	NT50, HSK80	1600, 4000

Tapping Spindle Head-Flange / Lead Screw Transmission

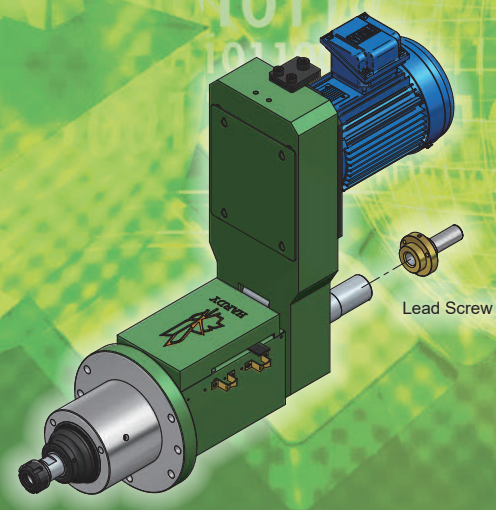

Roundness: $\leq 0.003\text{mm}$

Model	Max. Capacity (S45C)	Travel mm	Spindle Taper	Thread Guide Pitch mm
SFST06-65	M12	65mm	JT6, ER25, HSK40	0.4~2.0mm
SFST09-85	M30	85mm	NT30, HSK50	0.7~2.5mm
SFST12-90	M45	90mm	NT40, HSK63	0.8~3.0mm
SFST15-120	M50	120mm	NT50, HSK80	0.8~3.0mm

Drilling / Milling Spindle Head-Hydraulic Type

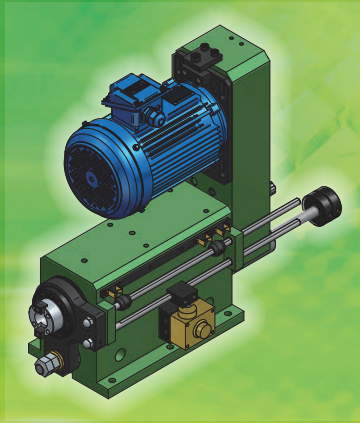

Roundness: $\leq 0.003\text{mm}$

Model	Max. Capacity (S45C)	Travel mm	Spindle Taper	Max. RPM
SD09-120	$\phi 25\text{ mm}$	120mm	NT30, HSK50	3000, 8000
SD12-150	$\phi 35\text{ mm}$	150mm	NT40, HSK63	2000, 6000
SD15-150	$\phi 50\text{ mm}$	150mm	NT50, HSK80	1600, 4000

Facing Spindle Head-Servo / Flange Type



TAIWAN
EXCELLENCE
2017

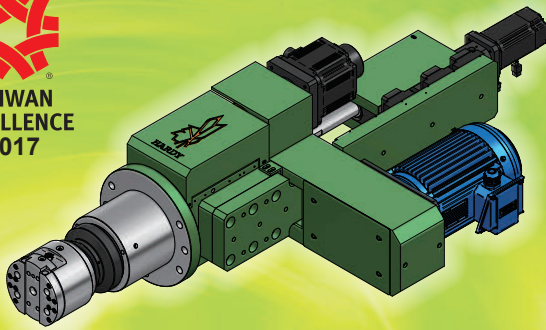

Roundness: $\leq 0.003\text{mm}$
Slider Self-Repeatability: $\leq 0.005\text{mm}$

Model	Facing Head	Facing Stroke	Spindle Stroke	Max. RPM
SSFSD09-120	FA408	8mm	120mm	1600
SSFSD11-120	FA408	8mm	120mm	1600
SSFSD12-150	FA610	10mm	150mm	1200
SSFSD15-150	FA812	12mm	150mm	800

Drilling Head Units

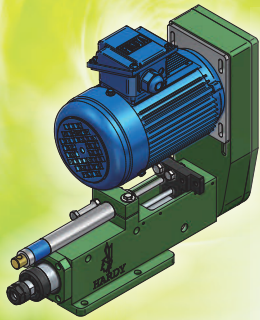

SD3, SD5

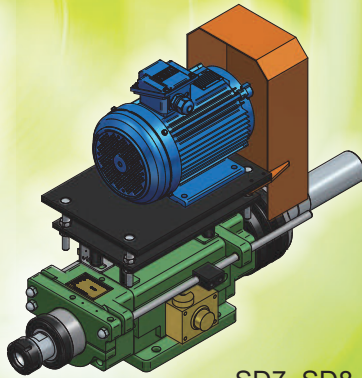

SD7, SD8

Roundness: $\leq 0.003\text{mm}$

Model	Max. Capacity (S45C)	Max. RPM	Propulsion
SD3-60M	$\phi 6\text{ mm}$	10000	Hydraulic or Pneumatic
SD3-80M	$\phi 6\text{ mm}$	10000	Hydraulic or Pneumatic
SD5-85M	$\phi 13\text{ mm}$	5000	Hydraulic or Pneumatic
SD7-130M	$\phi 20\text{ mm}$	2500	Hydraulic
SD8-150M	$\phi 35\text{ mm}$	1500	Hydraulic

Tapping Head Units

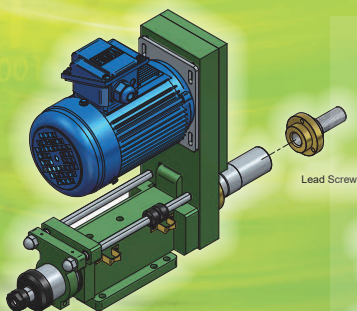

ST0N, ST1N, ST2N

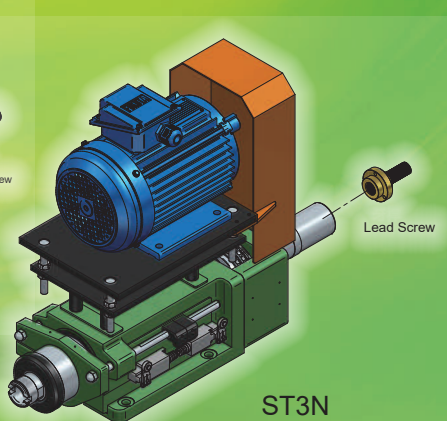

ST3N

Roundness: $\leq 0.003\text{mm}$

Model	Max. Capacity (S45C)	Thread Guide Pitch
ST0N-50M	M6	0.25~1.25mm
ST1N-65M	M12	0.4~2.0mm
ST2N-85M	M30	0.7~2.5mm
ST3N-90M	M45	0.8~3.0mm

Facing Spindle Head Unit-Servo Type

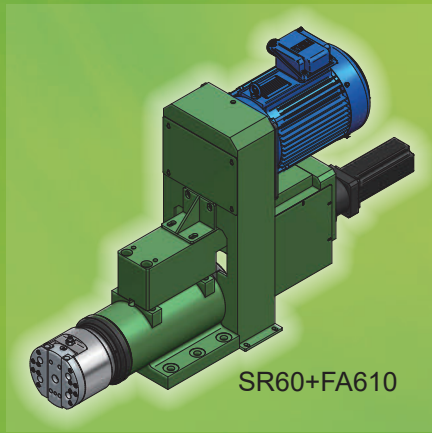

Roundness: $\leq 0.003\text{mm}$

Slider Self-Repeatability: $\leq 0.005\text{mm}$

Model	Facing Head	Facing Travel	Max. RPM
S55-FA408	FA408	8mm	1600
S60-FA610 SR60-FA610	FA610	10mm	1200
S80-FA812 SR80-FA812	FA812	12mm	800
S80-FD880 SR80-FD880	FD880	80mm	2500

Boring / Milling Head Unit

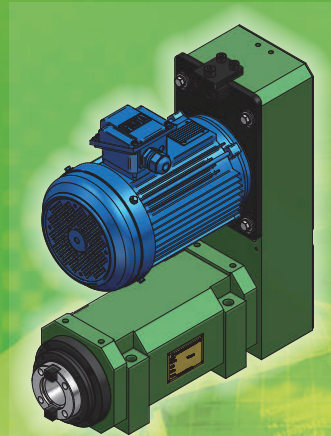
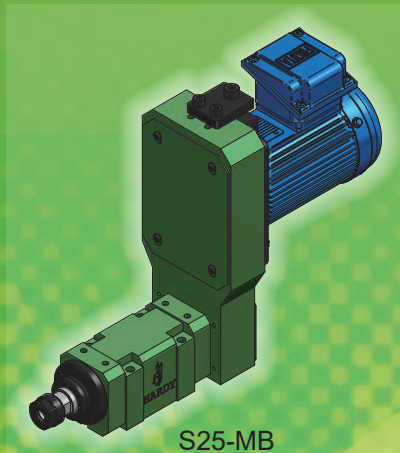

Roundness: $\leq 0.003\text{mm}$

Model	Spindle Taper	Max. RPM
S-25	ER20	4000 or 12000
S-35	MT3, ER32	3000 or 10000
S-45	NT30, ER40	2500 or 8000
S-55	NT40, MT4	2000 or 6000
S-60	NT40, A ₂ -4, FB50	1800 or 5000
S-75	NT50, FB75	1600 or 4000
S-80	NT50, A ₂ -5	1200 or 3000
S-100	NT50, A ₂ -6	800 or 2500
S-120	NT50, A ₂ -6	600 or 2000
SR-35	NT30	3000 or 10000
SR-45	NT40	2000 or 6000
SR-60	NT40, A ₂ -4, FB50	1800 or 5000
SR-80	NT50, A ₂ -5	1200 or 3000

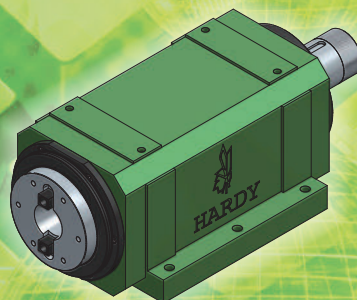
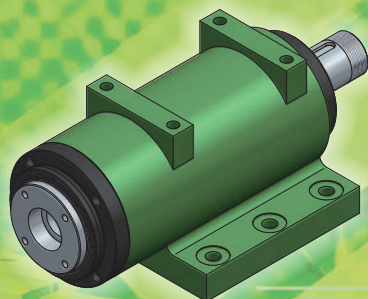

Boring / Milling Head Unit / Flange Type

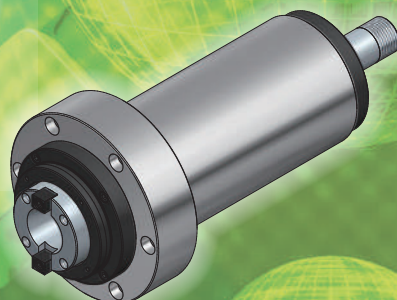
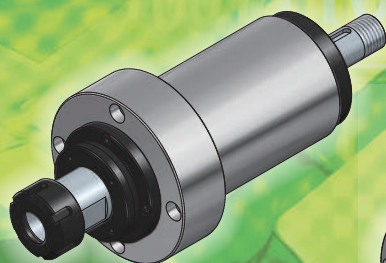

Roundness: $\leq 0.003\text{mm}$

Model	Spindle Taper	Max. RPM
SRR-35	MT3, ER32	3000 or 10000
SRR-45	NT30, ER40	2500 or 8000
SRR-55	NT40, MT4	2000 or 6000
SRR-60	NT40, A ₂ -4, FB50	1800 or 5000
SRR-75	NT50, FB75	1600 or 4000
SRR-80	NT50, A ₂ -5	1200 or 3000

Boring / Milling Head Unit / with Auto Unclamping Cylinder

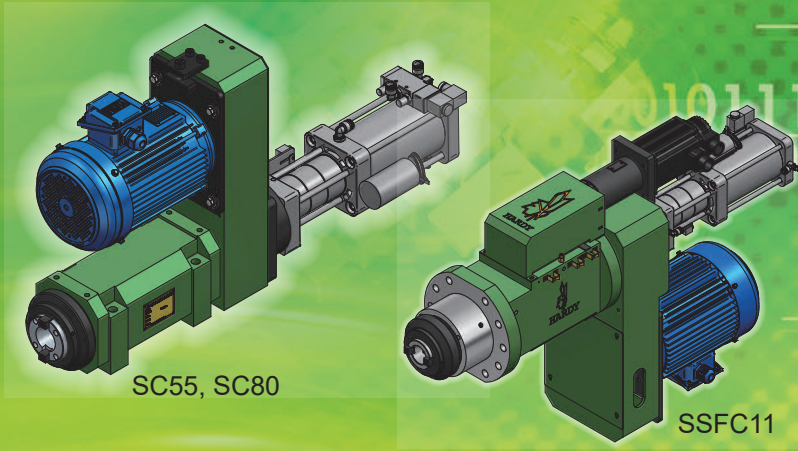

Roundness: $\leq 0.003\text{mm}$

Model	Spindle Taper	Max. RPM
SC55-BT40	BT40	2000 or 6000
SC80-BT50	BT50	1200 or 3000
SSFC11-BT40	BT40	1600 or 4000

Built-in Motor Spindle Unit

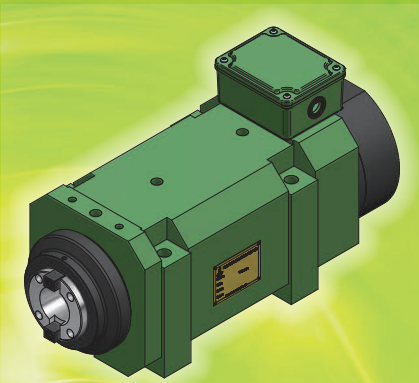

Roundness: $\leq 0.003\text{mm}$

Include driver / optional encoder

Model	Spindle Taper	Max. RPM	Power kW	Torque Nm	Coolant
SM55	NT40	2000	2.2	10.4	water
SM55H	NT40	6000	2.2	10.4	water

Water cooler not included

Vertical Slide Table / Servo Type

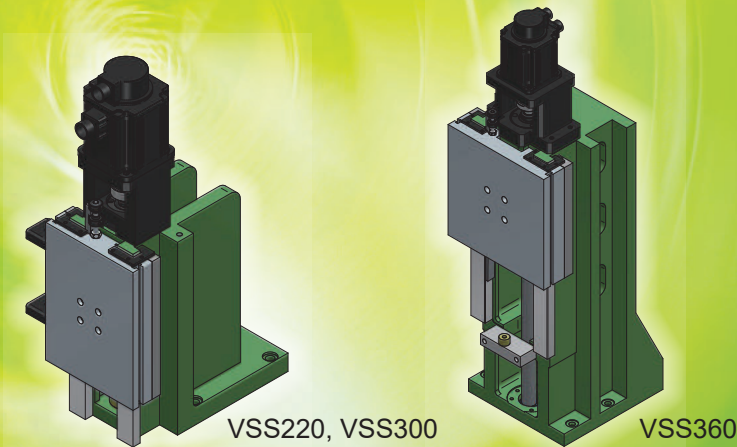

Perpendicularity : within 0.01mm / 100mm

Model	Width mm	Height mm	Travel mm
VSS220-300/420	220	420	100
VSS220-300/670	220	670	200
VSS300-360/540	300	540	120
VSS300-360/720	300	720	220
VSS360-360/920	360	920	260

Vertical Slide Table / Hydraulic Type

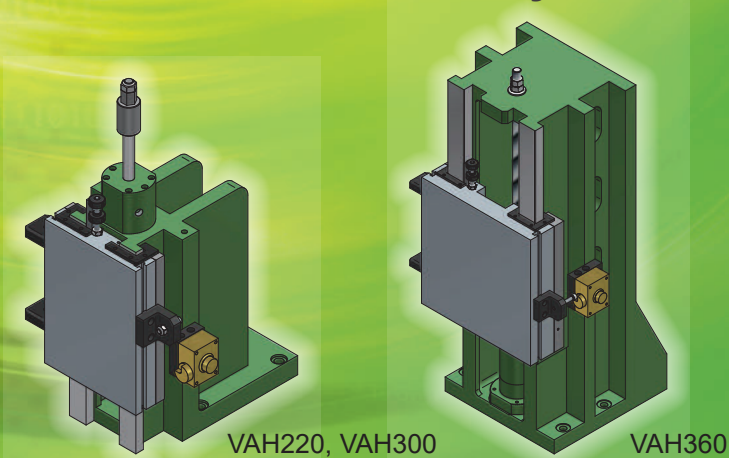

Perpendicularity : within 0.01mm / 100mm

Model	Width mm	Height mm	Travel mm
VAH220-300/420	220	420	100
VAH220-300/670	220	670	200
VAH300-360/540	300	540	120
VAH300-360/720	300	720	220
VAH360-360/920	360	920	260

Servo Slide Table / with Linear Guideway and Ball Screws

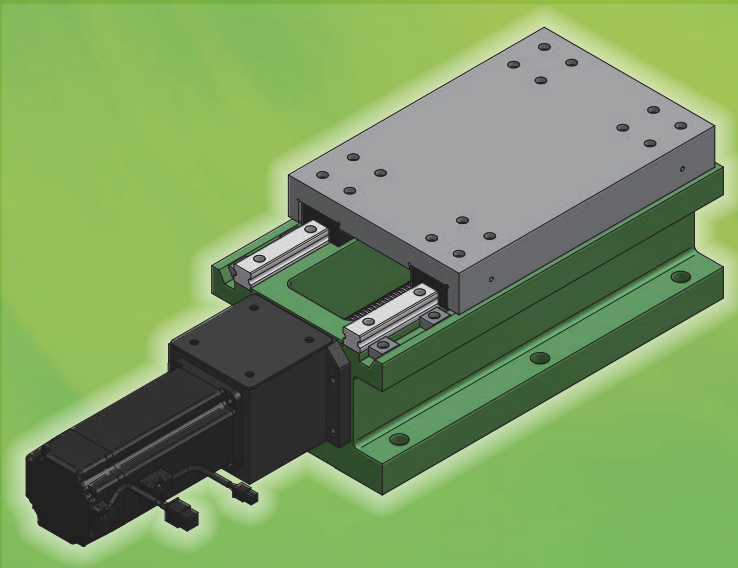

Parallelism & Flatness : within 0.01mm / 100mm

Model	Width mm	Length mm	Travel mm	Ball screw mm	Linear Rail width mm
RH150-400L	150	400	90	φ 20×5	20
RH200-400L	200	400	100		
RH200-640L		640	340	φ 25×5	25
RH250-520L	250	520	170		
RH250-760L		760	410		
RH250-1000L		1000	650		
RH300-520L	300	520	170	φ 25×5	25
RH300-760L		760	410		
RH300-1000L		1000	650		

Servo Slide Table / with Hardness Guideway and Ball Screw

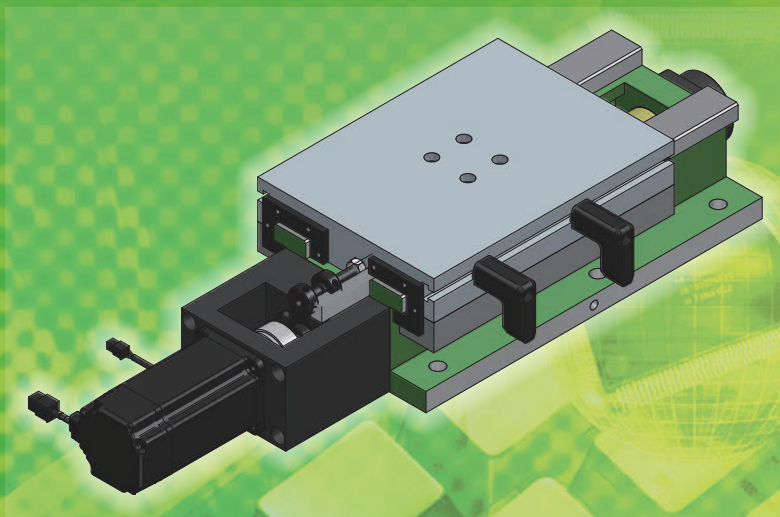

Parallelism & Flatness : within 0.01mm / 100mm
With Turcite for Guideway

Model	Width mm	Length mm	Travel mm
BS-150	150	300~400	80~180
BS-180	180	370~470	100~200
BS-220	220	420~940	100~500
BS-250	250	420~1200	100~760
BS-300	300	420~1200	100~760
BS-360	360	560~1200	180~580
BS-420	420	560~1200	120~580
BS-500	500	885~1800	345~1180
BS-600	600	885~1800	345~1180

Hydraulic Slide Table Unit

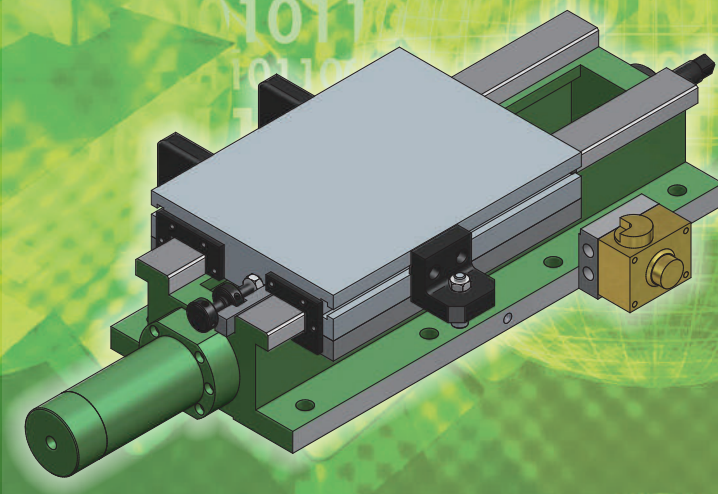

Parallelism & Flatness : within 0.01mm / 100mm

Model	Width mm	Length mm	Travel mm
HS-150	150	300~400	80~180
HS-180	180	370~470	100~200
HS-220	220	420~940	100~500
HS-250	250	420~1200	100~760
HS-300	300	420~1200	100~760
HS-360	360	560~1200	180~580
HS-420	420	560~1200	120~580
HS-500	500	885~1800	345~1180
HS-600	600	885~1800	345~1180

Vertical Cross Slide Table

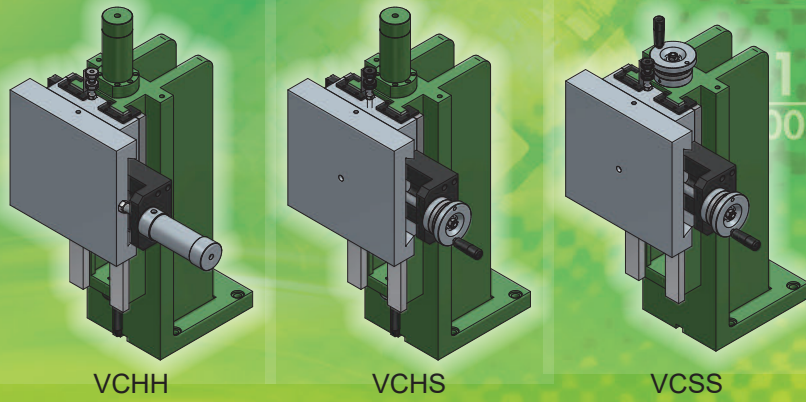

Perpendicularity : within 0.01mm / 100mm

Model	Width mm	Length mm	Travel mm
VCHH220-300/420	220	420	100
VCHH220-300/670	220	670	200
VCHH300-300/540	300	540	180
VCHH300-300/720	300	720	280

Vertical Slide Table / Lead Screw Type

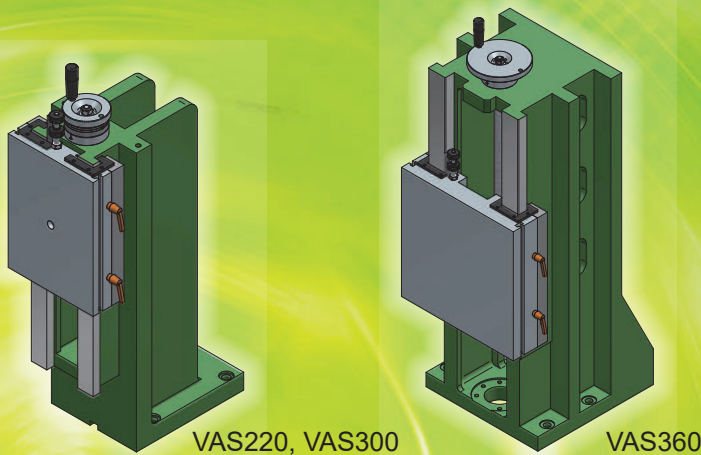

Perpendicularity : within 0.01mm / 100mm

Model	Width mm	Height mm	Travel mm
VAS220-300/420	220	420	100
VAS220-300/670	220	670	200
VAS300-360/540	300	540	120
VAS300-360/720	300	720	220
VAS360-360/920	360	920	260

Hydraulic Cross Slide Table

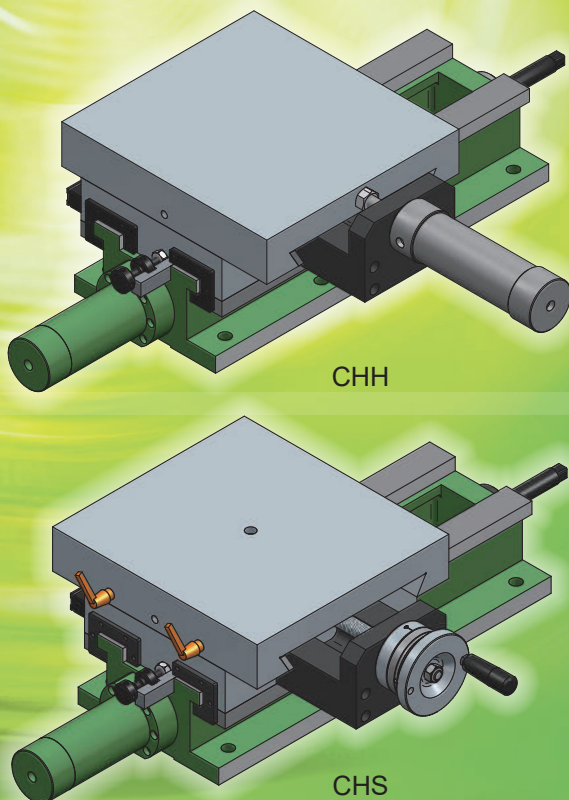

Parallelism & Flatness : within 0.01mm / 100mm
Cross Table With Servo Ball Screw is Available (CBB)

Model	Width mm	X Travel mm	Y Travel mm
CHS220-300/420	220	100	100
CHS220-300/520		200	
CHS220-300/670		350	
CHS220-300/800		480	
CHS220-300/940		620	
CHS300-300/420	300	100	100
CHS300-300/560		240	
CHS300-300/670		350	
CHS300-300/800		480	
CHS300-300/940		620	
CHS300-300/1200		880	

Drilling And Tapping Solutions In Industrial Automation

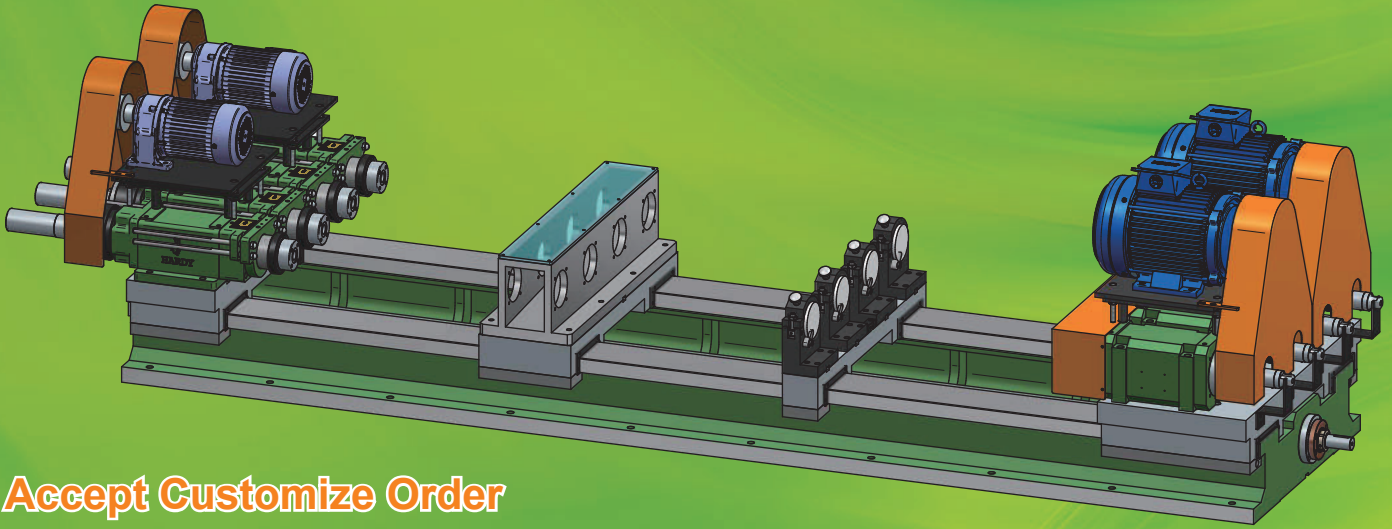

Accept Customize Order

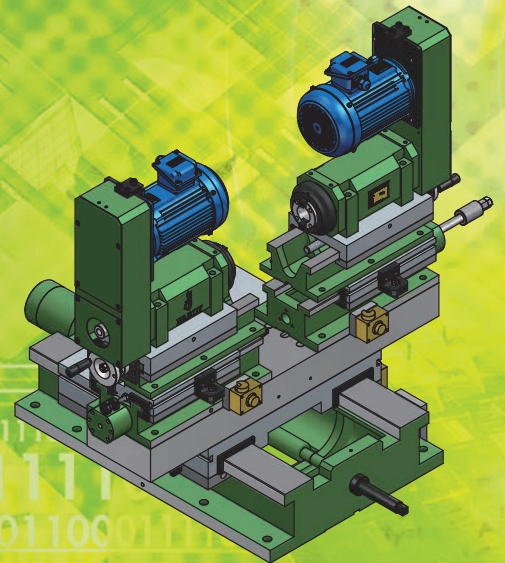
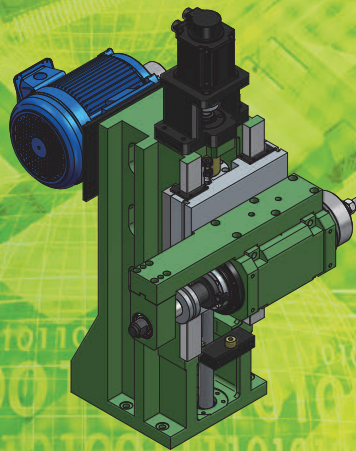
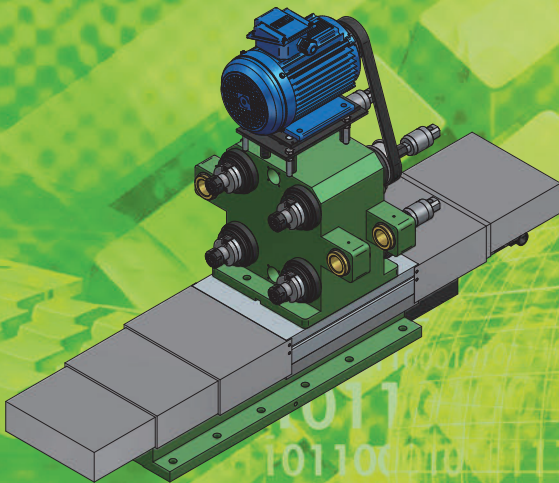
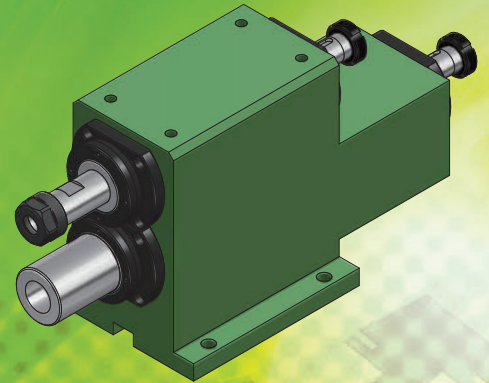
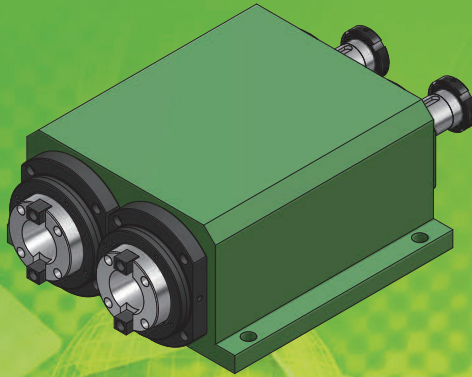
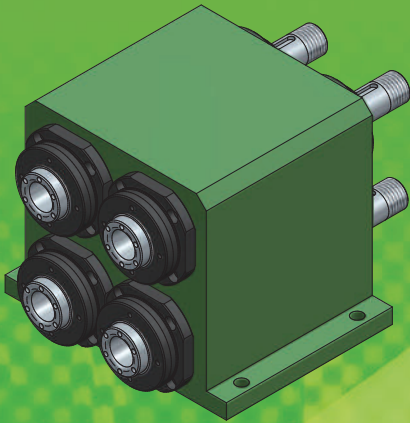

Authorised Distributors : Hann Kuen Machinery & Hardware Co., Ltd., Taiwan.

 **dolphin**
EXPORTS

ISO 9001:2015 CERTIFIED COMPANY

F-343, Phase-V, Focal Point, Ludhiana - 141 010 Punjab, India

Ph.: +91 161 5095142-43, +91 98550-09019

Email: info@dolphinexports.com, mfg@dolphinexports.com

www.dolphinexports.com



Certificate of Distributorship

THIS IS CERTIFY THAT

DOLPHIN EXPORTS

IS AN AUTHORIZED DISTRIBUTOR OF HANN KUEN MACHINERY & HARDWARE CO. LTD.

THIS CERTIFICATE IS VALID UNTIL END OF YEAR 2020



Linnan Kieny
General Manager